

# Genetic and Environmental Contributions to Sleep Quality and Low Back Pain: A Population-Based Twin Study

Marina B. Pinheiro, PhD, Jose J. Morosoli, MSc, Manuela L. Ferreira, PhD, Juan J. Madrid-Valero, MSc, Kathryn Refshauge, PhD, Paulo H. Ferreira, PhD, and Juan R. Ordoñana, PhD

## ABSTRACT

**Objective:** The aim of the study was to estimate the extent to which the co-occurrence of poor sleep quality and low back pain is due to the same genetic and/or environmental risk factors or due to a causal association.

**Methods:** Cross-sectional data on sleep quality (Pittsburgh Sleep Quality index) and low back pain were collected in a population-based sample of adult twins ( $N = 2134$ ) registered with the Murcia Twin Registry. Bivariate analysis and structural equation modeling were used.

**Results:** The phenotypic correlation between sleep quality and low back pain was 0.23 (95% confidence interval [CI] = 0.17–0.28). The best-fitting bivariate model included additive genetic and unique environmental factors. Genetic factors accounted for 26% (95% CI = 10–40) and 34% (95% CI = 25–43) of the variability of low back pain and sleep quality, respectively. The correlation between the genetic factors underlying each trait was  $r_G$  of 0.33 (95% CI = 0.03–0.66), and this overlap of genetic factors explained 42.5% of the phenotypic correlation. On the other hand, nonshared environmental factors of each variable were only fairly correlated  $r_E$  of 0.19 (95% CI = 0.06–0.31), although this overlap explained 57.5% of the phenotypic correlation. In addition, twins in monozygotic pairs with poorer sleep quality presented more often with low back pain than their co-twins ( $\hat{\rho} = 0.25, p < .0001$ ).

**Conclusions:** The data are compatible with a causal effect of sleep quality on low back pain (or the reverse effect), because the correlations between the genetic and unique environmental factors for each trait were significant and there was a significant correlation between the monozygotic twins' difference scores. Apart from environmental factors that affect both characteristics, there are many individual-specific events that influence low back pain but differ from those influencing sleep quality.

**Key words:** genetics, heritability, low back pain, sleep quality, twin studies.

## INTRODUCTION

Poor sleep quality is common. Approximately one third of the adult population is affected by some degree of sleep problems at any one time (1,2). Poor sleep quality has been associated with several adverse health outcomes, including increased risk of mortality (3), psychiatric disorders (4), hypertension (5), type 2 diabetes (6), cognitive impairments (7), and musculoskeletal pain complaints (8). Sleep problems, including poor sleep quality, are one of the most common comorbidities among patients with musculoskeletal pain (9), such as low back pain (10).

Low back pain is a major public health problem with critical consequences for psychological well-being (11,12). It affects approximately 12% of the population around the world at any one time (13), and it is considered the leading cause of disability globally when disability is defined as years lived with disability (14). The costs associated with low back pain are considerable and seem

to be rising (15). Estimates of the direct costs associated with low back pain in Europe varied between €187 million in Belgium to €4.2 billion in the Netherlands (16). In Spain, it was estimated that between 2000 and 2004, the annual average cost from lost working days due to low back pain was more than €160 million (17).

The prevalence of sleep problems with concurrent chronic low back pain is high, and this combination is associated with worse outcomes for patients, increasing psychological distress, and resulting in higher management costs (18–23). It is estimated that approximately 60% of people with low back pain also experience

–2LL = minus two times the log-likelihood, *df* = degrees of freedom, AIC = Akaike's information criterion, **A** = additive genetic factors, **C** = shared environmental factors, **E** = individual environmental factors, **D** = nonadditive genetic factors, **DZ** = dizygotic, **MTR** = Murcia Twin Registry, **MZ** = monozygotic, **PSQI** = Pittsburgh Sleep Quality Index, **SEM** = structural equation models

From the University of Sydney (Pinheiro, Refshauge, Ferreira), Faculty of Health Sciences, Australia; University of Murcia (Morosoli, Madrid-Valero, Ordoñana) Department of Human Anatomy and Psychobiology, and Murcia Institute of BioHealth Research (IMIB-Arrixaca-UMU), Spain; Department of Genetics and Computational Biology (Morosoli), QIMR Berghofer Medical Research Institute; School of Psychology (Morosoli), The University of Queensland, Brisbane, Australia; and Institute of Bone and Joint Research (Ferreira), The Kolling Institute, Sydney Medical School, The University of Sydney, Australia.

Address correspondence to Marina B. Pinheiro, PhD, Faculty of Health Sciences, The University of Sydney, 75 East St, Lidcombe, Sydney NSW 2141, Australia. E-mail: marina.pinheiro@sydney.edu.au

Paulo H. Ferreira and Juan R. Ordoñana share senior authorship.

The authors assert that all procedures contributing to this work comply with the ethical standards of the relevant national and institutional committees on human experimentation and with the Helsinki Declaration of 1975, as revised in 2008.

Received for publication May 25, 2017; revision received November 21, 2017.

DOI: 10.1097/PSY.0000000000000548

Copyright © 2017 by the American Psychosomatic Society

sleep problems (24,25). Although there are several studies demonstrating the link between low back pain and sleep quality (8,18,20), there is a paucity of studies exploring the nature and mechanisms underlying this association. Understanding such mechanisms could clarify the common pathways between them and potentially affect their management. For instance, if common genetic factors largely explained the covariance between them, a common physiological pathway would potentially be implied and its identification could ultimately prove helpful in treating comorbidity. However, if covariation depends on environmental factors common to both phenotypes, identifying and acting upon those common factors could prove effective in managing both conditions. Furthermore, if a causal path could be established between sleep quality and low back pain, interventions improving one of them would also result in improvement on the other, depending on direction of causality.

Previous studies have demonstrated the presence of a moderate to high heritability for sleep quality and also for low back pain when investigated in isolation (26–28). In addition, a recent study has explored the genetic correlation between pain in general and sleep quality (29) and found that the link between them is primarily explained by shared genetic influences between the two conditions. However, there is a range of factors that can affect such estimates, such as characteristics of the sample, including age, sex, geographical background, as well as how the conditions were defined and assessed (30,31). Thus, performing this investigation in a sample with different characteristics could expand our knowledge and understanding of the environmental and genetic contributions to the link between low back pain and sleep quality.

In addition, as demonstrated in previous works (29,32,33), it is possible to conduct a nonexperimental test of a causal relationship between two traits using cross-sectional twin data. In this type of investigation, two findings would suggest a causal link between sleep quality and low back pain (32): (1) the same genetic and environmental factors that influence one of the traits also influence the other, and (2) within monozygotic (MZ) twin pair differences in sleep quality are associated with within MZ twin pair differences in the prevalence of low back pain.

Therefore, the aim of this study was to determine the extent to which the association between sleep quality and low back pain results from common genetic and environmental factors, as well as to test whether the data support a causal link between them, by conducting a bivariate analysis in a large population-based sample of Spanish adult twins. Such a design allows the estimation of the relative importance of genetic and environmental influences on the variation of perceived sleep quality and low back pain, together with the genetic and environmental correlations between the two traits. The results from the bivariate genetic model were complemented by the analysis of the phenotypic cross-trait correlations between the within-trait difference scores in MZ twins.

## METHOD

### Participants

A population-based sample of female and male adult twins registered in the Murcia Twin Register (MTR) provided data for this study (34,35). The MTR reference population comprises all twin pairs who were born between 1940 and 1966 in the region of Murcia, Spain. The MTR has been approved by the Murcia University Ethical Committee and it follows national regulations regarding personal data protection. All applicable institutional

and governmental regulations concerning the ethical use of human volunteers were followed during this research. All participants have provided informed consent.

### Measures

Data were collected for female, male, and opposite-sex twin pairs using phone and face-to-face interviews between 2009 and 2011. The interview included demographic information and self-reported health-related questionnaires. All data were collected by trained assessors who were blinded to the predictors and outcome of the study. Data were retrospective and based on self-report information.

### Zygoty Ascertainment

Twin zygoty was determined by DNA tests in 338 twin pairs. For the remaining participants, a 12-item questionnaire focusing on the degree of similarity and mistaken identity between twins was used. This questionnaire-based zygoty corresponds well with zygoty determined by DNA testing, with an agreement in nearly 96% of participants (35).

### Assessment of Sleep Quality and Low Back Pain

Data on sleep quality were collected using the Pittsburgh Sleep Quality Questionnaire (36,37). The following seven areas of sleep are measured: subjective sleep quality, sleep latency, sleep duration, habitual sleep efficiency, sleep disturbances, use of sleeping medications, and daytime dysfunction during the last month. Each area provides a partial score (0–3). The sum of all seven partial results yields a global score, known as Pittsburgh Sleep Quality Index (PSQI), which indicates the overall sleep quality. Individuals scoring higher than 5 in PSQI are classified as poor sleepers and those who score 5 or less as good sleepers (36,37). The distribution of PSQI values was not normal, and data were log transformed to better meet the assumption of normality required by the linear regression, which was applied to adjust for the effects of age and sex.

Prevalence of low back pain was assessed through a dichotomous self-reported question derived from the Spanish National Health Survey. Participants were required to answer the following question: “Have you ever suffered from chronic low back pain?” and answers were dichotomized into two categories, yes or no. Chronic low back pain was explained to participants as pain in the lower back area that lasted for at least 6 months (including recurrent episodes).

### Statistical Analysis

#### Twin Data

The basic logic of twin studies can be summarized as follows: when phenotypic data are available on MZ and dizygotic (DZ) twin pairs, the total variance of the trait can be deconstructed to determine variance because of genetic and environmental factors. The genetic components can be divided into additive (A; i.e., summed allelic effects across multiple genes) and nonadditive (D; i.e., genetic dominance, possibly including epistasis) factors, whereas the environmental factors can be divided into shared (C; i.e., common/family environment) and individual or unique (E; i.e., idiosyncratic experiences, including measurement error) environmental factors. It is not possible to estimate C and D simultaneously in a classical twin model, and the choice of modeling C or D depends on the pattern of MZ and DZ correlations; usually C is estimated if the DZ twin correlation is more than half of the MZ twin correlation, and D is estimated if the DZ twin correlation is less than half of the MZ correlation (38,39). These different variance components may be estimated using twin data because MZ (identical twins) share 100% of their genes given they are originated from the same fertilized egg, whereas DZ twins (nonidentical) share on average 50% of their segregating genes (40). Comparing the resemblance (correlation) of MZ twins for a trait or disease with the resemblance of DZ twins for that trait or disease offers an estimate of the extent to which genetic variation determines phenotypic variation of that trait. A greater phenotypic

resemblance in MZ twin pairs compared with DZ twin pairs must be due to genetic influences (A or D components), considering the assumption that both MZ and DZ twins are exposed to equal shared environments (38).

If the association between two variables is analyzed, low back pain and sleep quality in the current study, the proportion of covariance on the traits explained by genetic and environmental factors can be estimated.

### Structural Equation Modeling

Structural equation models (SEM) offer a more precise way to estimate the variance that is explained by each of the latent components A, C, D, and E. SEM are commonly used in behavior genetics to this end because of their flexibility and precision; SEM take into account covariate effects, such as age or sex, compare the fit of various types of models, and provide confidence intervals for the estimates. Further details of the twin design can be found elsewhere (38,39,41).

In the present study, several models were tested. First, assumptions of the twin design were checked and univariate ACE-ADE models were fitted separately for each variable. Then, a joint ordinal-continuous bivariate Cholesky model (39) including both variables was fitted. This model was employed to estimate the extent to which genetic or environmental effects on one trait (e.g., low back pain) were correlated with these effects on another trait (e.g., sleep quality). In other words, it estimates the degree to which the same genes or environmental factors contribute to the observed phenotypic correlation of two variables.

Given that no specific causal order between sleep quality and low back pain was hypothesized, Cholesky estimations were transformed into a correlated factors model, which does not assume ordering of the variables (42). In this model, each variable is separately deconstructed into genetic and environmental components (latent variables) that account for all variance in

each phenotype. In addition, correlations of the latent genetic and environment variables across variables (low back pain and sleep quality) were estimated. A genetic correlation ( $r_G$ ) of 1.0 indicates that genetic influences on the two variables overlap completely, whereas a genetic correlation of 0 indicates that entirely different genes influence the two variables (Fig. 1). If the genetic and environmental correlations are both significant, that would support a causal explanation of the relationship between the two traits (32). On the contrary, if only one or none of them is significant, the causal hypothesis would be rejected.

In every case, nested submodels in which A component, either C or D components, or both (AC-AD) were fixed to zero, were tested against the full models. Following the principle of parsimony, if there was no statistically significant difference between two models, the simplest one was chosen. The fit of the different models and submodels was compared by the log-likelihood ratio test. The difference in minus two times the log-likelihood ( $-2LL$ ) between two models has a  $\chi^2$  distribution with the degrees of freedom ( $df$ ) equaling the difference in  $df$  between the two models. Moreover, model fit was evaluated using Akaike's information criterion (AIC) (43). AIC is a parsimony-adjusted statistic used to select among competing models. It reflects both the goodness of fit and parsimony of the models. This fit index is based on a hypothetical replication of the same population and of the same size as the analyses. The model with the smallest AIC is chosen as most likely to replicate. More complex models are less likely to replicate (44).

We considered correlations of less than 0.25 as low, between 0.25 and 0.50 as fair, between 0.50 and 0.75 as moderate to good, and greater than 0.75 as excellent (45). All models were fitted to the raw data using full information maximum likelihood using the R-package OpenMx v2.5.2 (46). Data preparation, as well as descriptive and preliminary analysis, was performed in R v3.2.5 (47).

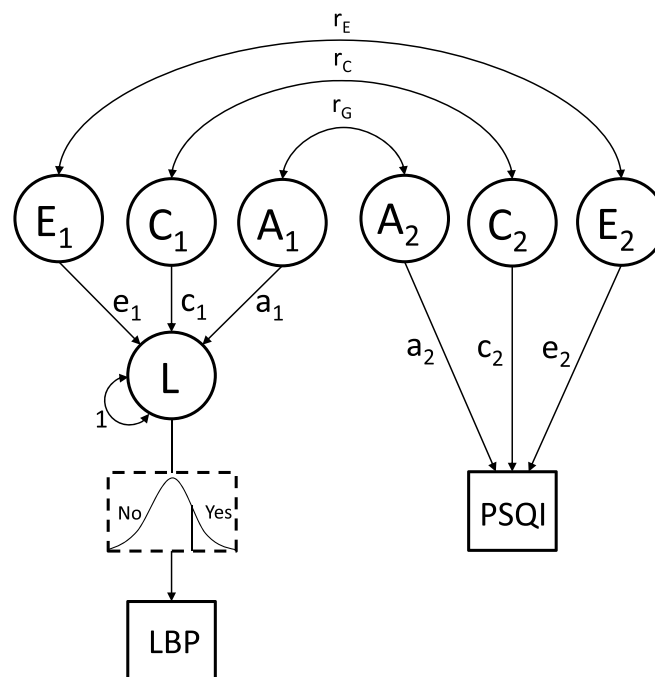

**FIGURE 1.** Path diagram of the bivariate model with the latent factors A, C, and E and their influence on the liability (propensity) to low back pain, as modeled in the liability-threshold model, and on sleep quality (PSQI). L = liability, LBP = low back pain, PSQI = Pittsburgh Sleep Quality Index. Variables in circles represent latent variables or factors. Variables in boxes represent observed (measured) variables. Single-headed arrows (paths) represent causal relationship between the latent and observed variables. Double-headed arrows define correlations between variables. Paths:  $a_{(1 \text{ or } 2)}$ ,  $c_{(1 \text{ or } 2)}$ ,  $e_{(1 \text{ or } 2)}$ , additive genetic, common environmental, and unshared environmental paths corresponding to univariate analyses of low back pain and PSQI. Correlations:  $r_G$ ,  $r_C$ , and  $r_E$ , additive genetic, common environmental, and unshared environmental correlations between corresponding components of low back pain and PSQI.

### Liability-Threshold Model

Low back pain was analyzed using a liability-threshold model (48). In this model, an unobserved liability underlying the measured categories of low back pain is assumed. The liability can be influenced either by the individual's genetic make-up or by the exposure to environmental factors. It is assumed to be normally distributed with a mean value of 0 and a variance of 1. Thresholds divide the underlying liability scale in regions or categories that are associated with specific observed phenotypes. The trait is expressed when the liability exceeds a certain threshold value.

Thresholds can be calculated as the number of standard deviations from the mean. By definition, the area under the curve corresponds to the probability to be in a certain category of low back pain or sleep quality (PSQI) (Fig. 1). Twin similarity is estimated by the polychoric correlation between the liability distributions.

Twin correlations and cross-trait cross-twin correlations (the correlation between low back pain in one twin and sleep quality in the co-twin) were estimated within a model, known as a saturated model, in which the correlations and thresholds are freely estimated over the different zygosity groups. The effect of age and sex was corrected by including both covariates as fixed effects in the model. Their coefficients were then dropped one by one and the difference in model fit was tested. Afterward, thresholds and means were constrained to be equal over the different groups to test for effects of twin order and zygosity. The fit of these models was compared with the saturated model.

To test whether sex and age had different effects on MZ and DZ twins, specific regression coefficients for each zygosity were modeled in a preliminary step. A regression model with the same coefficients for both zygosityes was tested against the model with different coefficients for them, using a log-likelihood ratio test.

### MZ Twin Intrapair Differences Model

Within-trait difference scores for sleep and low back pain were calculated for MZ twins. Following the assumption of low back pain data reflecting an underlying liability, the polyserial correlation between the two difference scores was estimated (49) using the R-package polycor v0.7-9 (50). A significant correlation between the within-trait differences in one trait with the within-trait differences in the other would support a causal relationship.

## RESULTS

A total of 2134 participants were included in this study. There were 1916 paired twins (325 MZ pairs, 351 same-sex DZ pairs, and 282 opposite-sex dizygotic OSDZ pairs) and 218 unpaired individual twins (45 MZ participants, 64 DZ participants, and 109 OSDZ participants). The mean (SD, range) age of the total sample was 53.7 (7.3, 43–71) years, and female participants accounted for 54.6% of the sample (Table 1).

There were no statistically significant differences ( $p < .05$ ) in prevalence of low back pain or mean PSQI score among members of the same twin pair or between MZ and DZ twins. In addition, the linear coefficients associated with each covariate could be equated between zygosity groups without a significant worsening of fit. In the saturated model, a significant effect of age and sex on PSQI score was found, but only age showed a significant effect on low back pain prevalence. Thresholds of low back pain, mean PSQI score, and variances of both variables could be constrained to be equal over all groups without a significant worsening of fit. Adding opposite-sex DZ pairs in the analysis did not change this outcome. Prevalence of low back pain and mean PSQI score (fixed to be equal across twin order), within zygosity groups, are shown in Table 1.

In the genetic analysis, MZ and DZ intratwin correlation patterns and model comparison led us to fit different variance models (e.g., ACE, ADE) for each variable in the univariate analyses. However, in the bivariate analysis, the ADE model showed the best fit (lowest  $-2LL$  and AIC values). Therefore, D factor was modeled, instead of C. Twin correlations and the cross-trait cross-twin correlations from the bivariate saturated model are presented in Table 2.

Comparison of ACE-ADE models and more restrictive AE models, including only additive genetic and unique environmental effects, showed no deterioration of fit after dropping C-D from the model, either in the univariate or the bivariate case, as indicated by the  $\chi^2$  and  $p$  value and also by the lowest AIC value. In all participants, omitting the common genetics pathway (A) led to a significant decrease in fit. This indicates that the additive genetics components are important to explain each phenotype (low back pain and PSQI) individually but also the covariance between them. All model comparisons are presented in Table 3.

The obtained maximum-likelihood path estimates of the A, C, D, and E variance components (e.g.,  $a_{(1,2)}$ ,  $c_{(1 \text{ or } 2)}$ ,  $e_{(1 \text{ or } 2)}$ ) were squared (e.g.,  $a_1^2$  and  $e_1^2$ ) to express the proportion of variance explained by each. These results are provided in Table 4. The heritability of low back pain was 26% (95% CI 10–40) and of sleep quality was 34% (95% CI 25–43).

The phenotypic, genetic, and unique environment correlations in the AE Model were, respectively,  $r_{ph} = 0.23$  (0.17–0.28),  $r_G = 0.33$  (0.03–0.66); and  $r_E = 0.19$  (0.06–0.31). The percentage of covariance between low back pain and sleep quality attributable to the additive genetic factor (A) was 42.5% and to the unique environmental factors (E) was 57.5%. In addition, the phenotypic

**TABLE 1.** Characteristics of Included Participants, According to Zygosity

	Total		MZ		DZ	
	<i>n</i>	Mean (SD, Range) or %	<i>n</i>	Mean (SD, Range) or %	<i>n</i>	Mean (SD, Range) or %
Age, y	2134	53.7(7.3, 43–71)	695	52.2(7.0, 43–70)	1439	54.4(7.4, 43–71)
Sex (female)	1165	54.6	409	58.8	756	52.5
PSQI score (continuous)	1912	5.1(4.0, 0–19)	644	5.2(3.9, 0–19)	1268	5.1(4.0, 0–19)
PSQI > 5 (poor sleepers)	731	38.2	251	39.0	480	37.8
LBP (yes)	689	32.3	236	33.9	453	31.5

MZ = monozygotic; DZ = dizygotic; PSQI = Pittsburgh Sleep Quality Index; LBP = low back pain; y = years.

**TABLE 2.** Twin Correlations Based on Maximum Likelihood Estimation With 95% CIs

	LBP Twin Correlation	PSQI Twin Correlation	Cross-Trait Cross-Twin Correlation
MZ	0.25 (0.07 to 0.42)	0.37 (0.26 to 0.46)	0.10 (0.00 to 0.20)
DZ	0.14 (0.00 to 0.27)	0.13 (0.04 to 0.22)	0.05 (−0.03 to 0.12)

LBP = low back pain; PSQI = Pittsburgh Sleep Quality Index; MZ = monozygotic; DZ = dizygotic.

cross-trait correlation between the intrapair MZ difference scores was a  $\hat{\rho}$  value of 0.25 (SE = 0.06,  $p < .0001$ ).

## DISCUSSION

### Summary

In this study, we analyzed the association between perceived sleep quality and persistent low back pain by addressing the structure of the covariance between them. The phenotypic correlation between sleep quality and low back pain was 0.23 (95% CI = 0.17–0.28) and unique environmental factors explained 57.5% of the covariance between them. The remaining 42.5% of the covariance between low back pain and sleep quality was explained by genetic factors. There was a fair ( $r_G = 0.33$ , 95% CI = 0.03–0.66) correlation between the genetic factors influencing each trait suggesting that, to some extent, there is an overlap in the set of genes affecting both sleep quality and low back pain. An overlap was also found for unique environmental factors evidenced by a low correlation, indicating that the types of individual-specific events that influence low back pain are not necessarily the same as those influencing sleep quality. However, the correlation between the genetic and unique environmental factors influencing each variable (i.e., sleep quality and low back pain) was significant. This is compatible with a causal relationship in either direction. A possible causal relationship is further supported by the fact that the intrapair MZ differences in low back pain correlated significantly with the differences in sleep quality.

### Comparison With Previous Investigations

The heritability estimates from the univariate analysis were considered fair and estimated at 26% for low back pain and 34% for sleep quality. Those estimates are in accordance with previous studies suggesting that the low back pain heritability can range between 21% and 67% (26), whereas the heritability for sleep quality ranges from 33% to 44% (27–29,51). However, a recent study has found higher genetic correlation for the association between overall pain and sleep quality ( $r_G = 0.69$ , 95% CI = 0.33–0.97) than the present study, suggesting that this relationship was primarily explained by shared genetic influences (29). There are a number of factors that could account for the discrepancies in results. Firstly, the sample size investigated by Gasperi et al. (2007) (29) was smaller than the present study (400 versus 2134), which affects the level of precision and generalisability of their findings. Secondly, this previous study investigated younger participants (average age of 29 years), from a diverse background (US), and these factors have been reported to affect genetics and environmental estimates (30,31). Lastly, we have investigated lifetime prevalence of chronic low back pain as opposed to recent or current pain, and this might partially explain the higher phenotypic association and genetic estimates found by Gasperi et al. (2007) (29). Given the range of factors that might affect the association between pain and sleep quality, investigating the contribution of genetic and environmental factors across various samples can enhance our understanding of such relationship.

**TABLE 3.** Model Fitting Results for the Univariate and Bivariate Models of Low Back Pain and Sleep Quality (PSQI)

Variables	Model	−2LL	AIC	Parameters	Comparison	$\chi^2$	$\Delta df$	$p$
LBP	1. ADE model	2580.403	−1671.597	6				
	2. ACE model	2580.340	−1671.660	6				
	<b>3. AE model</b>	<b>2580.403</b>	<b>−1673.597</b>	<b>5</b>	<b>ACE model</b>	<b>0.063</b>	<b>1</b>	<b>.802</b>
	4. CE model	2581.226	−1672.774	5	ACE model	0.886	1	.347
	5. E model	2592.485	−1663.515	4	AE model	12.082	2	<.001
Sleep quality (PSQI)	1. ACE model	5335.248	1523.248	6				
	2. ADE model	5334.123	1522.123	6				
	<b>3. AE model</b>	<b>5335.248</b>	<b>1521.248</b>	<b>5</b>	<b>ADE model</b>	<b>1.125</b>	<b>1</b>	<b>.289</b>
	4. E model	5377.290	1561.290	4	AE model	42.042	1	<.0001
LBP and sleep quality (PSQI)	1. ADE model	7857.512	−202.488	15				
	2. ACE model	7858.689	−201.311	15				
	<b>3. AE model</b>	<b>7858.728</b>	<b>−207.272</b>	<b>12</b>	<b>ADE model</b>	<b>1.216</b>	<b>3</b>	<b>.749</b>
	4. E model	7912.512	−159.488	9	AE model	53.784	3	<.0001

AIC = Akaike's Information Criterion; −2LL = negative 2 log-likelihood;  $df$  = degrees of freedom; LBP = low back pain; PSQI = Pittsburgh Sleep Quality Index; A = additive genetic influences; C = common environmental influences; D = nonadditive genetic effects; E = unique environmental influences.

The best-fitting model is shown in bold.

**TABLE 4.** Estimates of Additive Genetic (A), Nonadditive Genetic (D), Shared Environmental (C), and Unique Environmental (E) Variance Components for Low Back Pain and Sleep Quality, Computed From Bivariate Cholesky Decomposition Model (Correlated Factors Solution)

		Cholesky Model (Correlated Factor Solution)		
		$a^2$ (95% CI)	$c^2$ or $d^2$ (95% CI)	$e^2$ (95% CI)
ACE model	Low back pain	0.22 (0.00–0.40)	0.03 (0.00–0.27)	0.75 (0.60–0.91)
	Sleep quality	0.34 (0.17–0.43)	0.00 (0.00–0.12)	0.66 (0.57–0.75)
ADE model	Low back pain	0.26 (0.00–0.40)	0.00 (0.00–0.40)	0.74 (0.58–0.89)
	Sleep quality	0.14 (0.00–0.42)	0.23 (0.00–0.46)	0.63 (0.53–0.74)
AE model	Low back pain	0.26 (0.10–0.40)	0*	0.74 (0.59–0.90)
	Sleep quality	0.34 (0.25–0.43)	0*	0.66 (0.57–0.75)

CI = confidence interval.

\*Fixed value.

Our results further support the finding of the previously mentioned study (29) regarding the compatibility of the obtained results with a causal relationship between sleep quality and pain. Although the results of the current study are not a definite proof of a causal explanation and does not exclude pleiotropy, the pattern of correlations found is coherent with the causal hypothesis. Direction of causation cannot be tested with these data and requires additional longitudinal data. Additional support for a causal effect of low back pain on sleep quality also comes from a previous study conducted by our group using this same sample. We found sleep quality to be an important covariate while analyzing the effect of symptoms of depression on low back pain, revealing a strong association (odds ratio = 2.42, 95% CI = 1.27–4.61) between poor sleep quality and low back pain in MZ twins discordant for the latter (11). Furthermore, a recent cohort study investigating 461 participants who received care for low back pain found that improvement in sleep quality is associated with improvement in low back pain symptoms, providing further support to a possible causal effect of low back pain explaining part of the association between these traits (52). Establishing such causality is important as it implies a potential for therapeutic intervention. Future longitudinal studies are needed to confirm the results of the present study and to investigate direction of causation.

Our best-fitting model included only additive genetic (A) and individual-specific environmental factors (E) for all models, meaning that shared environment (C) probably does not have a noticeable effect on the studied traits in adults. These findings are in accordance with previous studies investigating heritability of low back pain in adults or the association between pain and sleep quality, where shared environment was not an important component (29,53,54). In contrast, studies investigating low back pain in younger participants have shown that shared environmental factors are important in children (55), but as people get older, the effect of nonshared environment increases while the effect of shared environment becomes unimportant (55,56). Similarly, studies investigating heritability of sleep quality have consistently found that the effect of shared environmental factors for many sleep phenotypes reduces over the years and is negligible in adults (27), possibly because the amount of shared experiences between twins decreases with age.

### Interpretation of Results and Implications

Although we found a statistically significant phenotypic correlation between sleep quality and low back pain, such correlation was low (0.23, 95% CI = 0.17–0.28). This estimate was, at first sight, lower than expected, given the number of published studies supporting the relationship between these traits. However, we investigated a sample from the general population, and it is possible that the association is weaker in samples derived from the general population than clinical samples and there is evidence that heritability estimates vary according to severity of poor sleep quality and low back pain symptoms (26,27). For instance, the mean PSQI score found in this study was very close to 5 (5.1), suggesting that most participants were considered to be good sleepers (62%).

Based on the results of this study, the logical next step would be to identify unique environmental factors that influence each or both of the studied traits and genes that influence sleep quality and low back pain. The possible causal relationship between them would imply that acting on factors that positively affect one of the studied variables has the potential to influence the other. For instance, interventions proven to be effective in improving sleep quality, such as cognitive behavioral therapy (57,58), would have the potential to also improve pain in patients experiencing sleep problems and low back pain. However, given the weak phenotypic association found in this study, finding unique environmental factors that influence each condition might be more relevant and more likely to contribute to identification of effective, targeted prevention, and intervention strategies. Therefore, modifiable environmental factors that influence each variable (i.e., sleep quality and low back pain) independently should be investigated.

The finding that there is an overlap in the genetic effects influencing low back pain and sleep quality highlights the importance of common biological mechanisms underlying associations between these variables. Previous studies have demonstrated that poor sleep quality reduces the cognitive ability to manage pain and significantly change pain threshold, reducing pain tolerance (59). Although the mechanisms are not completely understood, a possible explanation is that pain changes dopamine signaling, which in turn could affect sleep quality, because dopamine plays an essential role in the sleep-wake regulation (60,61). It has also been proposed that poor sleep quality may affect pain processing by changes in the central inhibitory and facilitating mechanisms,

causing a state of generalized hyperalgesia (60). However, it is important to highlight that the mentioned genetic covariance must be observed within the context of a low phenotypic correlation.

According to the results of this study, genetic factors explained 42.5% of the covariance between sleep quality and low back pain this suggests that future studies investigating the association between these traits, including randomized controlled trials, should consider adjusting for genetic effects, because these factors play a nonnegligible role on the association. Twin studies can be used to further our understanding of the association between sleep quality and low back pain, as they allow optimal adjustment for confounding, including genetic factors (40). This approach is currently being tested by our group in the implementation of the first randomized co-twin controlled trial in sleep and back pain (62).

### Limitations

Although this study has included a large sample ( $N = 2134$  participants) that is representative of the population (63), some of our estimates are surrounded by wide confidence intervals and should be interpreted with caution and our results should be confirmed in future studies. In addition, we did not test models of direction of causation because these analyses require larger sample sizes and repeated measures (64). However, these models should be investigated in the future to fully explore the plausible causal relationship between low back pain and sleep quality.

We found high values for the E component in the univariate models. The E component, in addition to individual environmental factors, also includes the error component. The potential sources of error from this study could include the sample size, as well as the measurement properties of instruments used to assess both low back pain and sleep quality. Models including several indicators for each condition would allow disentangling the influence of measurement error from the nonshared environmental effect.

The instrument used to measure low back pain was generic and did not take into account other important descriptors of the condition, such as severity of symptoms, disability levels, and care-seeking behavior. This is particularly important because there is evidence that the genetic component of low back pain varies depending on how the condition is described, being higher for more chronic and disabling cases than for acute and less disabling ones (26). Therefore, the definition of low back pain used, i.e., lifetime chronic low back pain, as well as the sample characteristics, should be taken into consideration when interpreting the findings of the present study. In addition, any reporting of a history of pain inevitably depends on recall. Although the possibility of recall bias in our data cannot be disregarded, there is no reason to suspect a differential recall bias between MZ and DZ twins, and therefore, recall bias is unlikely to have a significant influence on our results. Although there is evidence of good validity for the instrument used to assess sleep quality (PSQI), it is important to note that this is a subjective sleep quality measure rather than an objective one and does not reflect specific sleep disorders. Lastly, the single measure commonly used in the literature to assess low back pain may not gather important information regarding the patient trajectory over time. It has been suggested that trajectory patterns may represent an additional practical phenotype for studying low back pain and that this perspective has a great potential for enhancing our understanding of factors that affect the course of low back pain (65). Future analyses should take into account this approach.

### CONCLUSIONS

Our data suggest a causal relationship between sleep quality and low back pain. Most of the covariance between these traits (57.5%) is attributable to unique environmental factors, whereas the remainder is explained by genetic factors (42.5%). A proportion of the genetic influences on low back pain is shared with genetic factors influencing sleep quality, suggesting that there is an overlap between the set of genes influencing sleep quality and low back pain. In addition, a small but significant proportion of the types of individual-specific events that influence low back pain also influence sleep quality. These results should be confirmed in future studies employing a longitudinal design. Our results highlight the complexity of the relationship between low back pain and sleep quality and provide additional insight into the potential mechanisms underlying the association.

*The authors would like to acknowledge the support and contribution of the Murcia Twin Registry for the implementation of this study.*

*Source of Funding and Conflicts of Interest: The Murcia Twin Registry is supported by Fundación Séneca, Regional Agency for Science and Technology, Murcia, Spain (15302/PHCS/10 & 19479/PI/14) and Ministry of Economy and Competitiveness, Spain (PSI11560–2009 & PSI2014-56680-R) including FEDER co-funding granted to JRO. MLF holds a Sydney Medical Foundation Fellowship, The University of Sydney. JJMV holds a FPI Scholarship from Fundación Séneca, Murcia, Spain (19814/FPI/15).*

### REFERENCES

- Ohayon MM. Epidemiology of insomnia: what we know and what we still need to learn. *Sleep Med Rev* 2002;6:97–111.
- Madrid-Valero JJ, Martínez-Selva JM, Ribeiro do Couto B, Sánchez-Romera JF, Ordoñana JR. Age and gender effects on the prevalence of poor sleep quality in the adult population. *Gac Sanit* 2017;31:18–22.
- Hublin C, Partinen M, Koskenvuo M, Kaprio J. Heritability and mortality risk of insomnia-related symptoms: a genetic epidemiologic study in a population-based twin cohort. *Sleep* 2011;34:957–64.
- Breslau N, Roth T, Rosenthal L, Andreski P. Sleep disturbance and psychiatric disorders: a longitudinal epidemiological study of young adults. *Biol Psychiatry* 1996;39:411–8.
- Fang J, Wheaton AG, Keenan NL, Greenlund KJ, Perry GS, Croft JB. Association of sleep duration and hypertension among US adults varies by age and sex. *Am J Hypertens* 2012;25:335–41.
- Cappuccio FP, D'Elia L, Strazzullo P, Miller MA. Quantity and quality of sleep and incidence of type 2 diabetes: a systematic review and meta-analysis. *Diabetes Care* 2010;33:414–20.
- Potvin O, Lorrain D, Forget H, Dube M, Grenier S, Preville M, Hudon C. Sleep quality and 1-year incident cognitive impairment in community-dwelling older adults. *Sleep* 2012;35:491–9.
- Bonvanie JJ, Oldehinkel AJ, Rosmalen JG, Janssens KA. Sleep problems and pain: a longitudinal cohort study in emerging adults. *Pain* 2016;157:957–63.
- Roehrs T, Roth T. Sleep and pain: interaction of two vital functions. *Semin Neurol* 2005;25:106–16.
- Serrano-Aguilar P, Kovacs FM, Cabrera-Hernandez JM, Ramos-Goni JM, Garcia-Perez L. Avoidable costs of physical treatments for chronic back, neck and shoulder pain within the Spanish National Health Service: a cross-sectional study. *BMC Musculoskelet Disord* 2011;12:287.
- Pinheiro MB, Ferreira ML, Refshauge K, Colodro-Conde L, Carrillo E, Hopper JL, Ordoñana JR, Ferreira PH. Genetics and the environment affect the relationship between depression and low back pain: a co-twin control study of Spanish twins. *Pain* 2015;156:496–503.
- Pinheiro MB, Ferreira ML, Refshauge K, Maher CG, Ordoñana JR, Andrade TB, Tsathas A, Ferreira PH. Symptoms of depression as a prognostic factor for low back pain: a systematic review. *Spine J* 2016;16:105–16.
- Hoy D, Bain C, Williams G, March L, Brooks P, Blyth F, Woolf A, Vos T, Buchbinder R. A systematic review of the global prevalence of low back pain. *Arthritis Rheum* 2012;64:2028–37.
- Global Burden of Disease Study C. Global, regional, and national incidence, prevalence, and years lived with disability for 301 acute and chronic diseases

- and injuries in 188 countries, 1990–2013: a systematic analysis for the Global Burden of Disease Study 2013. *Lancet* 2015;386:743–800.
15. Martin BI, Deyo RA, Mirza SK, Turner JA, Comstock BA, Hollingworth W, Sullivan SD. Expenditures and health status among adults with back and neck problems. *JAMA* 2008;299:656–64.
  16. Dagenais S, Caro J, Haldeman S. A systematic review of low back pain cost of illness studies in the United States and internationally. *Spine J* 2008;8:8–20.
  17. Salvans MM, Gonzalez-Viejo MA. Disability by low back pain in Spain from 2000 to 2004 [in Spanish]. *Med Clin (Barc)* 2008;131:319.
  18. Alsaadi SM, McAuley JH, Hush JM, Lo S, Bartlett DJ, Grunstein RR, Maher CG. The bidirectional relationship between pain intensity and sleep disturbance/quality in patients with low back pain. *Clin J Pain* 2014;30:755–65.
  19. Ropponen A, Silventoinen K, Hublin C, Svedberg P, Koskenvuo M, Kaprio J. Sleep patterns as predictors for disability pension due to low back diagnoses: a 23-year longitudinal study of Finnish twins. *Sleep* 2013;36:891–7.
  20. Kelly GA, Blake C, Power CK, O’Keefe D, Fullen BM. The association between chronic low back pain and sleep: a systematic review. *Clin J Pain* 2011;27:169–81.
  21. Baumeister H, Knecht A, Hutter N. Direct and indirect costs in persons with chronic back pain and comorbid mental disorders—a systematic review. *J Psychosom Res* 2012;73:79–85.
  22. Edit V, Eva S, Maria K, Istvan R, Agnes C, Zsolt N, Eva P, Laszlo H, Peter TI, Emese K, Klara T, Gyula P, Edit V, Eva S, Maria K, Istvan R, Agnes C, Zsolt N, Eva P, Laszlo H, Peter TI, Emese K, Klara T, Gyula P. Psychosocial, educational, and somatic factors in chronic nonspecific low back pain. *Rheumatol Int* 2013;33:587–92.
  23. Ritzwoller DP, Crouse L, Shetterly S, Rublee D. The association of comorbidities, utilization and costs for patients identified with low back pain. *BMC Musculoskelet Disord* 2006;7:72.
  24. Alsaadi SM, McAuley JH, Hush JM, Maher CG. Erratum to: prevalence of sleep disturbance in patients with low back pain. *Eur Spine J* 2012;21:554–60.
  25. Axen I. Pain-related sleep disturbance: a prospective study with repeated measures. *Clin J Pain* 2016;32:254–9.
  26. Ferreira PH, Beckenkamp P, Maher CG, Hopper JL, Ferreira ML. Nature or nurture in low back pain? Results of a systematic review of studies based on twin samples. *Eur J Pain* 2013;17:957–71.
  27. Genderson MR, Rana BK, Panizzon MS, Grant MD, Toomey R, Jacobson KC, Xian H, Cronin-Golomb A, Franz CE, Kremen WS, Lyons MJ. Genetic and environmental influences on sleep quality in middle-aged men: a twin study. *J Sleep Res* 2013;22:519–26.
  28. Barclay NL, Eley TC, Buysse DJ, Archer SN, Gregory AM. Diurnal preference and sleep quality: same genes? A study of young adult twins. *Chronobiol Int* 2010;27:278–96.
  29. Gasperi M, Herbert M, Schur E, Buchwald D, Afari N. Genetic and environmental influences on sleep, pain, and depression symptoms in a community sample of twins. *Psychosom Med* 2017;79:646–654.
  30. MacGregor AJ, Snieder H, Schork NJ, Spector TD. Twins. Novel uses to study complex traits and genetic diseases. *Trends Genet* 2000;16:131–4.
  31. Snieder H, MacGregor AJ, Spector TD. *Advances in Twin and Sib-pair Analysis*, London: Cambridge University Press; 2000.
  32. De Moor MH, Boomsma DI, Stubbe JH, Willemsen G, de Geus EJ. Testing causality in the association between regular exercise and symptoms of anxiety and depression. *Arch Gen Psychiatry* 2008;65:897–905.
  33. Bartels M, de Moor MH, van der Aa N, Boomsma DI, de Geus EJ. Regular exercise, subjective wellbeing, and internalizing problems in adolescence: causality or genetic pleiotropy? *Front Genet* 2012;3:4.
  34. Ordoñana JR, Perez-Riquelme F, Gonzalez-Javier F, Carrillo E, Gomez-Amor J, Martinez-Selva JM. An initiative in Spain for the study of women’s health: the Murcia Twin Registry. *Twin Res Hum Genet* 2006;9:865–7.
  35. Ordoñana JR, Rebollo-Mesa I, Carrillo E, Colodro-Conde L, Garcia-Palomo FJ, Gonzalez-Javier F, Sanchez-Romera JF, Oviedo JMA, de Pancorbo MM, Perez-Riquelme F. The Murcia Twin Registry: a population-based registry of adult multiples in Spain. *Twin Res Hum Genet* 2013;16:302–6.
  36. Buysse DJ, Reynolds CF, Monk TH, Berman SR, Kupfer DJ. The Pittsburgh Sleep Quality Index: a new instrument for psychiatric practice and research. *Psychiatry Res* 1989;28:193–213.
  37. Royuela Rico A, Macías Fernández JA. Propiedades clinimétricas de la versión castellana del cuestionario de Pittsburgh. *Vigilia-Sueño* 1997;9:81–94.
  38. Verweij KJ, Mosing MA, Zietsch BP, Medland SE. Estimating heritability from twin studies. *Methods Mol Biol* 2012;850:151–70.
  39. Neale M, Cardon L. *Methodology for Genetic Studies of Twins and Families*, Dordrecht, the Netherlands: Kluwer; 1992.
  40. Boomsma D, Busjahn A, Peltonen L. *Classical twin studies and beyond*. *Nat Rev Genet* 2002;3:872–82.
  41. Posthuma D, Beem AL, de Geus EJ, van Baal GC, von Hjelmborg JB, Iachine I, Boomsma DI. Theory and practice in quantitative genetics. *Twin Res* 2003;6:361–76.
  42. Loehlin JC. The Cholesky approach: a cautionary note. *Behav Genet* 1996;26:65–9.
  43. Akaike H. Factor analysis and AIC. *Psychometrika* 1987;52:317–32.
  44. Kline RB. *Principles and Practice of Structural Equation Modeling*, 2nd ed. New York: Guilford Press; 2005.
  45. Portney LG, Watkins MP. *Foundations of Clinical Research: Applications to Practice*, 3rd ed. Upper Saddle River, NJ: Pearson & Prentice Hall; 2009.
  46. Neale MC, Hunter MD, Pritikin JN, Zahery M, Brick TR, Kirkpatrick RM, Estabrook R, Bates TC, Maes HH, Boker SM. *OpenMx 2.0: extended structural equation and statistical modeling*. *Psychometrika* 2016;81:535–49.
  47. R Core Team. *A Language and Environment for Statistical Computing*, Vienna, Austria: R Foundation for Statistical Computing; 2016.
  48. Rijdsdijk FV, Sham PC. Analytic approaches to twin data using structural equation models. *Brief Bioinform* 2002;3:119–33.
  49. Drasgow F. Polychoric and Polyserial Correlations. *The Encyclopedia of Statistics*, New York, NY: John Wiley; 1986:68–74.
  50. Fox J. Polycor: Polychoric and Polyserial Correlations. R package version 0.7-9. 2016 [18/10/2017]. Available at: <https://CRAN.R-project.org/package=polycor>. Accessed October 18, 2017.
  51. Partinen M, Kaprio J, Koskenvuo M, Putkonen P, Langinvainio H. Genetic and environmental determination of human sleep. *Sleep* 1983;6:179–85.
  52. Kovacs FM, Seco J, Royuela A, Betegon JN, Sanchez-Herraez S, Meli M, Martinez Rodriguez ME, Nunez M, Alvarez-Galovich L, Moya J, Sanchez C, Luna S, Borrego P, Moix J, Rodriguez-Perez V, Torres-Unda J, Burgos-Alonso N, Gago-Fernandez I, Gonzalez-Rubio Y, Abraira V. The association between sleep quality, low back pain and disability: a prospective study in routine practice. *Eur J Pain* 2017.
  53. Battie MC, Videman T, Levalhti E, Gill K, Kaprio J. Heritability of low back pain and the role of disc degeneration. *Pain* 2007;131:272–80.
  54. MacGregor AJ, Andrew T, Sambrook PN, Spector TD. Structural, psychological, and genetic influences on low back and neck pain: a study of adult female twins. *Arthritis Rheum* 2004;51:160–7.
  55. Hestbaek L, Iachine IA, Leboeuf-Yde C, Kyvik KO, Manniche C. Heredity of low back pain in a young population: a classical twin study. *Twin Res* 2004;7:16–26.
  56. El-Metwally A, Mikkelsen M, Stahl M, Macfarlane GJ, Jones GT, Pulkkinen L, Rose RJ, Kaprio J. Genetic and environmental influences on non-specific low back pain in children: a twin study. *Eur Spine J* 2008;17:502–8.
  57. Wu JQ, Appleman ER, Salazar RD, Ong JC. Cognitive behavioral therapy for insomnia comorbid with psychiatric and medical conditions: a meta-analysis. *JAMA Intern Med* 2015;175:1461–72.
  58. Trauer JM, Qian MY, Doyle JS, SM WR, Cunningham D. Cognitive behavioral therapy for chronic insomnia: a systematic review and meta-analysis. *Ann Intern Med* 2015.
  59. Kundermann B, Krieg JC, Schreiber W, Lautenbacher S. The effect of sleep deprivation on pain. *Pain Res Manag* 2004;9:25–32.
  60. Sivertsen B, Lallukka T, Petrie KJ, Steingrimsdottir OA, Stubhaug A, Nielsen CS. Sleep and pain sensitivity in adults. *Pain* 2015;156:1433–9.
  61. Monti JM, Monti D. The involvement of dopamine in the modulation of sleep and waking. *Sleep Med Rev* 2007;11:113–33.
  62. Pinheiro MB, Ho KK, Ferreira ML, Refshauge KM, Grunstein R, Hopper JL, Maher CG, Koes BW, Ordoñana JR, Ferreira PH. Efficacy of a sleep quality intervention in people with low back pain: protocol for a feasibility randomized co-twin controlled trial. *Twin Res Hum Genet* 2016:1–10.
  63. Ordoñana JR, Sánchez-Romera JF, Colodro-Conde L, Carrillo E, González-Javier F, Madrid-Valero JJ, Morosoli JJ, Pérez-Riquelme F, Martínez-Selva JM. The Murcia Twin Registry. A resource for research on health-related behaviors. *Gac Sanit* 2018;32:92–95.
  64. Neale MC, Kendler KS. Models of comorbidity for multifactorial disorders. *Am J Hum Genet* 1995;57:935–53.
  65. Kongsted A, Kent P, Axen I, Downie AS, Dunn KM. What have we learned from ten years of trajectory research in low back pain? *BMC Musculoskelet Disord* 2016;17.